

INSTALLATION INSTRUCTIONS

PARTS & TOOLS

PARTS PER HYDRANT :
(Each box contains 4 complete enclosures)

2 ENCLOSURE HALVES
2 BRACKET HALVES WITH ATTACHED TABS
10 - #8 X 1" STAINLESS STEEL SCREWS
4 SERRATED 5/16" X 1.25" NUTS & BOLTS
MOUNTING TAPE & 3/16" RUBBER SHIMS
1 REFLECTIVE POST

REQUIRED TOOLS

PHILLIPS DRIVER; 1/2" WRENCH, CLAMPS

ATTACH BRACKET TO HYDRANT

1. SNAP OFF TABS AND SET TABS INSIDE OF BRACKET SECTIONS AT THE LETTERS THAT APPROXIMATE THE DIAMETER OF THE HYDRANT BARREL: TEST THE FIT BY HOLDING THE BRACKET HALVES AT THE INTENDED LEVEL OF INSTALLATION. A - 7.125" DIAMETER; B - 7.750" DIAMETER; C - 8.375" DIAMETER. USE DIAMETER COMBINATIONS AND/OR RUBBER SHIMS TO ENSURE A TIGHT FIT.

2. SET THE BRACKET "**THIS SIDE UP**" AROUND THE HYDRANT BARREL UNDER THE HOSE VALVE CAPS. THE SEAM BETWEEN THE TWO BRACKET HALVES SHOULD BE SET **PERPENDICULAR** TO THE STREET.

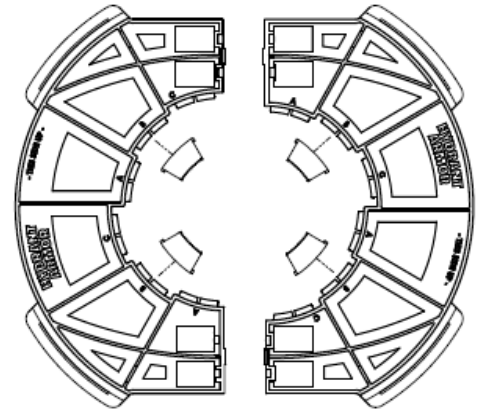

3. ATTACH MOUNTING TAPE (AND ADHEASIVE BACKED RUBBER SHIMS AS NECESSARY) TO THE TAB ENDS PRIOR TO BOLTING THE BRACKET HALVES TOGETHER, THEN INSTALL THE BOLTS AND TIGHTEN. USE CLAMPS TO HOLD BRACKET HALVES IN PLACE WHILE SETTING BOLTS.

ENSURE THE BRACKET FITS TIGHTLY TO THE HYDRANT AND IS IMMOVABLE.

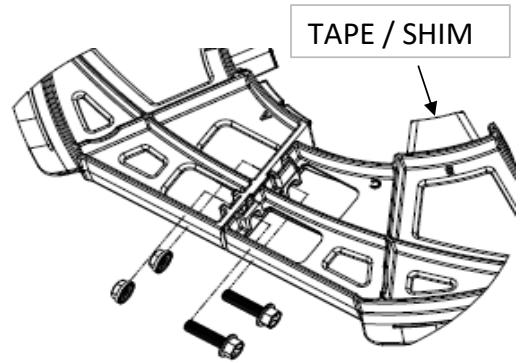

ATTACH ENCLOSURE TO BRACKET

4. "SANDWICH" THE POST INSIDE THE ENCLOSURE HALVES. SET THE BOTTOM OF THE REFLECTIVE POST IN THE CAP AND ATTACH THE TWO HALVES OF THE ENCLOSURE TOGETHER WITH THE SCREWS PROVIDED.

5. PLACE ASSEMBLED ENCLOSURE SQUARELY OVER BRACKET, THEN TURN THE ENCLOSURE 45° TO SET AND LOCK. THE SEAM SHOULD BE **PERPENDICULAR** TO THE STREET. WHEN LOCKED INTO POSITION, THE ENCLOSURE WILL REQUIRE MODERATE FORCE TO REMOVE.

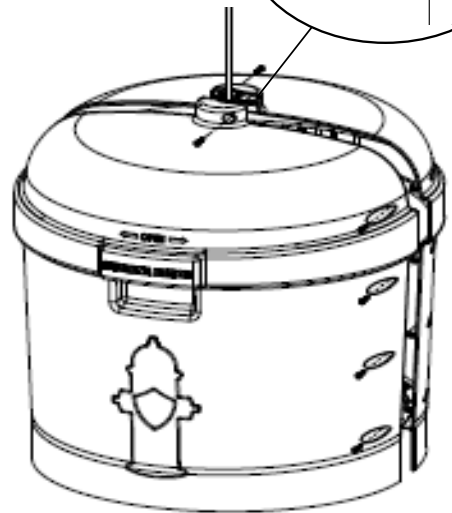
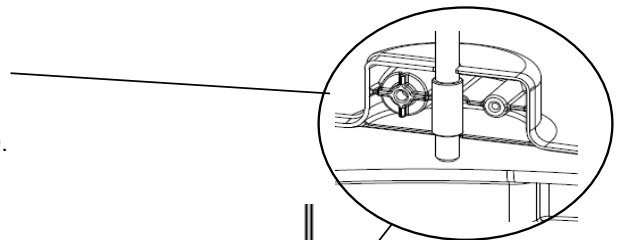

INTERIOR VIEW OF BRACKET AND ENCLOSURE. BRACKET TABS LOCK INTO CHANNEL AT BOTTOM OF ENCLOSURE.

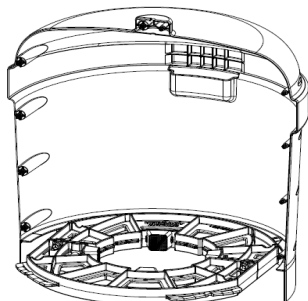

*